

SP4000

SP4000 P925169 00001

Incorporated control panel:
SIRIO TEL

- Great reliability in intensive use with the SP4000 irreversible operator.
- Special treatment guarantees protection from bad weather.
- Release manoeuvre by means of a mechanical key-release device.
- Hydrodynamic joint coupling for smooth gate starting and stopping operations.
- Self-braking motor.



Operator	SP4000
Power supply	three-phase 400 Vac \pm 10%, 60Hz
Absorbed power	1500 W
Protection	overload cut out inside the panel
Max leaf weight	40000 N (~ 4000 kg)
Output revolutions	30 min ⁻¹
Pinion pitch	6mm (18 teeth)
Leaf speed	10 m/min
Impact reaction	with edge and/or external devices
Manual manoeuvre	mechanical key-release device
Number of manoeuvres in 24 hours	continuous service
Control unit	SIRIO TEL
Type of limit device	electromechanical
Environmental conditions	from -15°C to +50°C
Degree of protection	IP 24
Operator weight	850 N (~85 kg)
Dimensions	see drawing

Electromechanical operator for rack sliding gates weighing up to 4000 kg, for industrial use

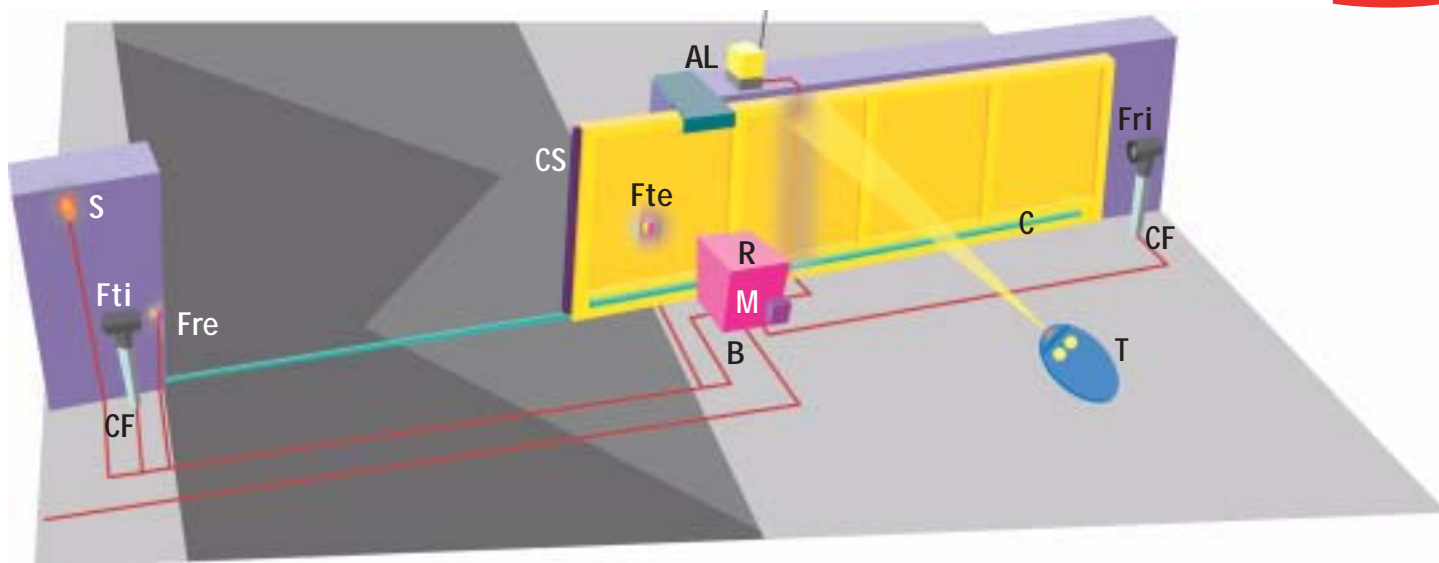

Example of installation

- M operator, SP4000 with incorporated SIRIO TEL control panel
- R single-channel rolling-code receiver, suitable for Mitto transmitter
- T double-channel rolling-code transmitter, Mitto 2 12V
- Ftx-Frx Pair of photocells, Cellula 50
- CF Pair of post, CC50
- AL blinker with antenna
- S key selector, Intro
- C rack, CFZ6, pitch 6 - 30x30
- B BASP adjustable anchor base for SP4000
- CS safety edge

• For system layout and installation conditions, refer to the standards and laws in force in the country of installation.

Dimensions

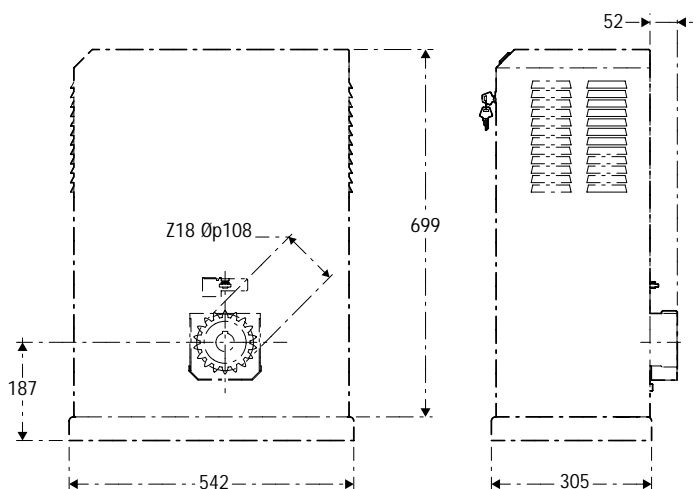

Main characteristics

- Irreversible type electromechanical operator for the automation of sliding gates for industrial use •
- SP4000 is provided with a control panel having a removable terminal bar and self-diagnosis LED
- self-braking motor • hydrodynamic joint coupling • three-phase overload cutout • manual release
- SIRIO TEL control panel • Main specifications: supply 400 Vac three-phase $\pm 10\%$ 50Hz • power 1500W • leaf speed 10m/min • max leaf weight 40000N (~4000 kg).

Contact:

Randa Trading & Contracting Co. Ltd.
Tel: 474 8881 / Fax: 477 7827.

